

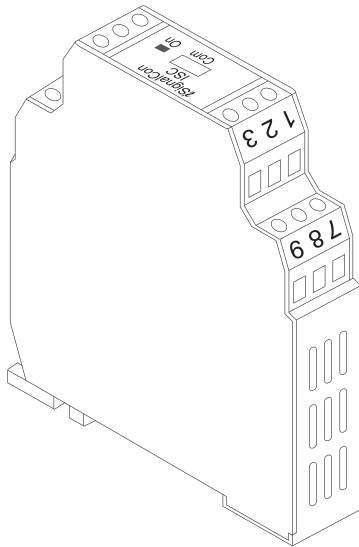

## 2-Channel Isolated Universal Signal Converter/Conditioner/Isolator

Model ISC

### Installation and Operation Guide



SignalCon® Model ISC is a user programmable 2-channel isolated universal signal converter. Microprocessor based designed make it flexible to accept various input signals including mV, V, mA, PT100 and 9 different thermocouples. The measuring unit and range are also configurable with a user-friendly software SignalWin® via PC.

#### Features

- The unique Math function
 
$$f(PV_1, PV_2) \propto \sqrt{\frac{PV_1 \times A \times PV_2 \times B}{C}}$$
 PV1, PV2 is the measuring value of Channel 1 and Channel 2 separately. A, B, C is a constant set by user.
- The unique High/Low comparison output  
The output 1 will scale to PV1 or PV2 whichever is higher/lower than the other.
- Programmable for various input signals, measuring range.
- Easy configuration without external power connected.
- Dual channel Input :
  - Resistance thermometer (Pt100)
  - Thermocouple (J, K, T, E, B, R, S, N, C)
  - Voltage/Current transmitter (mV/V/mA)
- Dual analog output (ISC-D) :  
0/4 to 20mA or 0~10V analogue output.
- RS485 communication with Modbus RTU protocol. (ISC-C)
- Fault signal on sensor break presettable.

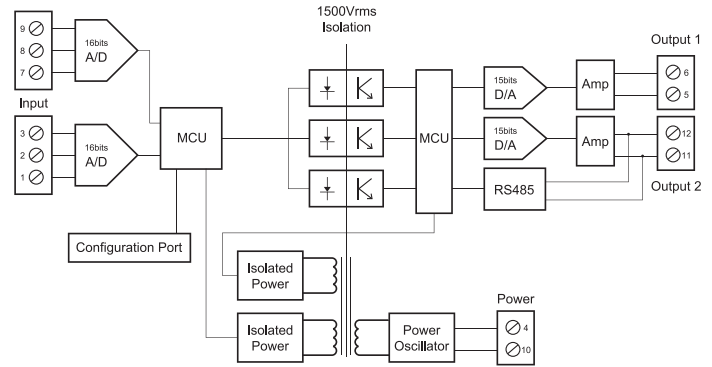

#### Specification

- Input signal** : User programmable. refer to table 1.
- Thermocouple (T/C) : industry standard thermocouple types, J, K, T, E, B, R, S, N, C (ITS-90).
  - Pt100 : Excitation 180uA. 2 or 3 wire connection (ITS-90  $\alpha=0.00385$ ).
  - Voltage : -60mVdc to 60mVdc or -10Vdc to 10Vdc.
  - Current : 0mA to 24mA
- Measuring range** : User programmable. Maximum range refer to table 1.
- Measuring accuracy** : refer to Table 1. the accuracy is tested under the operating condition of 24°C±3°C.
- Input sampling rate** : 200mS.

Input signal	Maximum Range	Accuracy
Thermocouple J	-50 to 1000°C (-58 to 1832°F)	±1°C
Thermocouple K	-50 to 1370°C (-58 to 2498°F)	±1°C
Thermocouple T	-270 to 400°C (-454 to 752°F)	±1°C
Thermocouple E	-50 to 700°C (-58 to 1292°F)	±1°C
Thermocouple B	0 to 1750°C (32 to 3182°F)	±2°C (Note1)
Thermocouple R	-50 to 1750°C (-58 to 3182°F)	±2°C
Thermocouple S	-50 to 1750°C (-58 to 3182°F)	±2°C
Thermocouple N	-50 to 1300°C (-58 to 2372°F)	±2°C
Thermocouple C	-50 to 1800°C (-58 to 3272°F)	±2°C
Pt100	-200 to 600°C (-328 to 1112°F)	±0.2°C
MV	-60mV to 60mV	±0.01mV
Voltage (Note2)	-10 to 10Vdc	±1mV
Current (Note2)	0 to 24mAdc	±10µA

#### \*Factory Setting

**Note 1** : Accuracy is not guaranteed between 0 and 400°C (0 and 752°F) for type B, R and S.

**Note 2** : The internal jumper should be set. See Table 2 in detail.

**Table 1 Input Signal**

- Output signal** : DC 4/0~20mA or DC 0~10V
- Output resolution** : 0.6uA.
- Output response time** : <200mS.
- Communication** : Modbus RTU protocol, 2400~38400 bps
- Power supply** : 18~36 Vdc, internal protection against polarity inversion.
- Power Consumption** : 2W max.
- Galvanic isolation** : 2 KV 1min. between input and output
- Operating temperature** : 0 to 55°C
- Humidity** : 0 to 90% RH
- Electromagnetic compatibility (EMC)** : En 50081-2, En 50082-2
- Dimension** : shown in Figure 1.
- Housing material** : ABS plastic. UL 94V0
- Weight** : 85g

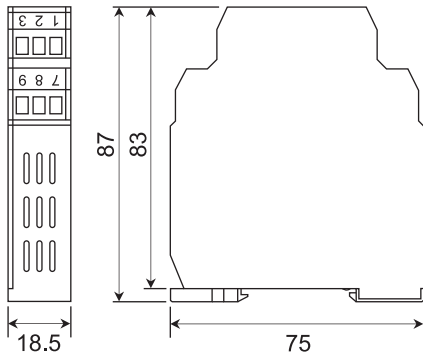
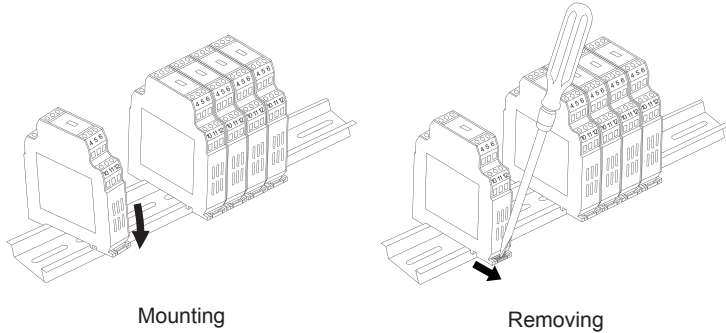

Figure 1. Dimension in mm

## Installation



## Electrical Connection

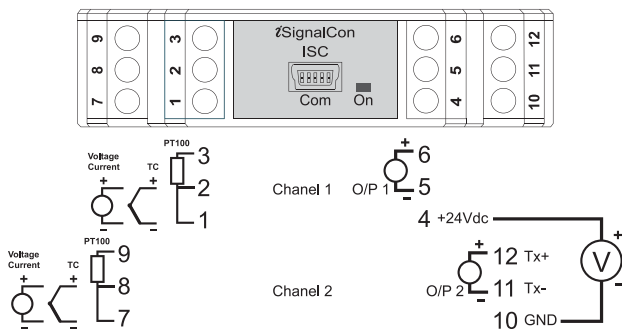

Figure 2. Terminal connections

### Wiring Specification :

- Screw tightening torque : 4.3 lb-in.
- Wire range : 12~30 AWG.
- Wire strip length : 7mm.

### Wiring Precaution :

1. Always keep signal wires away from power or contactor wires.
2. The power supply of iSignalCon® should not be shared with contactors, electrical motor and other inductive devices.

The various input signals are divided into three groups.

1. TC/RTD/mV : Thermocouple type (J, K, T, E, B, R, S, N, C), Pt100 and voltage input in the range of -60mVdc~60mVdc.
2. Current : 0~24mA
3. Voltage : -10~10Vdc.

For the three different groups of input signal type, The SW1 and SW2 should be set according to the Table 2 for each channel separately.

	1	2	3
TC/RTD/mV*	OFF	OFF	ON
0~24mA	ON	OFF	ON
-10V~10V	OFF	ON	OFF

\*Factory Setting

Table 2. Internal DIP switch setting

To change the DIP switch setting, please open the iSignalCon® cover as shown in Figure 3.

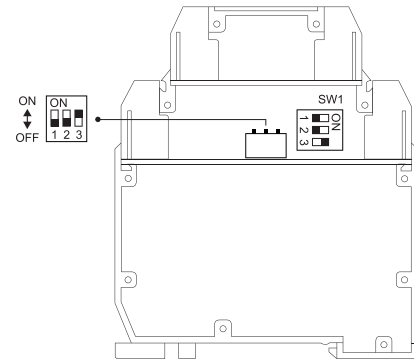

Figure 3. Internal DIP switch

## Communication

The iSignalCon® can be optional equipped with RS-485 interface. Further information about the communication please refer to "ISC Operation manual"

## Configuration

All input signals and the output are calibrated within the specified accuracy at factory. However, a recalibration is implemented to provide fine adjustments to the output signal in the field.

The iSignalCon® is user configurable by the PC software iSignalWin® along with the URC-1020 interface cable or the EzPro hand held programmer.

- iSignalWin® is user-friendly software. The latest release version can be download free from [www.vertex-tw.com](http://www.vertex-tw.com)
- URC-1020 Interface cable consist of interface converter and USB plug. It can be purchased separately from iSignalCon® supplier.

During configuration the iSignalCon® can work alone without connecting to a power source. The configuration connection is shown in Figure 4.

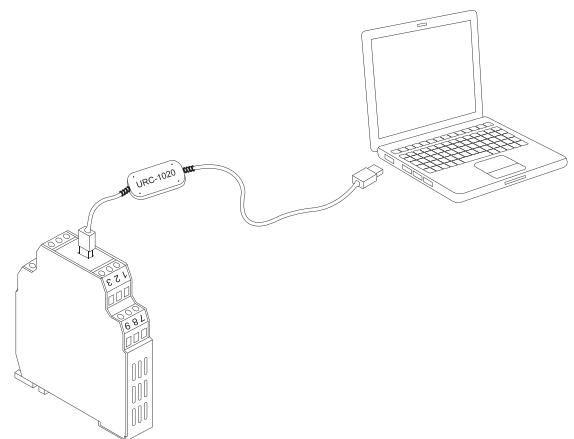

Figure 4. Configuration connection

Figure 5 show the configuration screen of iSignalWin®. The help menu provides further detail information about the software and the ISC converter. The Configurable parameters are :

1. **Input signal type** : Various input signal type can be selected among the available options.
2. **Measuring range** : Defines the lowest and highest value of measuring range. Within the range, the iSignalCon® converting input signals into an scalable analogue output signal.
3. **Unit** : Select the unit (°C or °F) of temperature measurement. For linear input (voltage or current), it doesn't effect the measurement.

4. **Output direction** : Defines the scalable analogue output signal to be 4 to 20mA or 20 to 4mA.
5. **Fault signal on sensor break** : Defines the output signal to be
  - (1) Downscale (<4mA).
  - (2) upscale (>20mA).
  - (3) Cut. Limit the output signal within the output range when the input is out of measuring range.
6. **Offset Correction** : Allows to eliminate the offset error of measuring value.
7. **ID and Baud Rate** : Set device ID and communication baud rate.
8. **Output Function** : Select output 1 to be
  - (1) scale to channel 1 measuring value (PV1).
  - (2) Math function, which make it possible to be used as signal addition/subtraction/division/square-root converter.
  - (3) High/Low comparison of PV1, PV2 the output 1 will scale to PV1 or PV2 whichever is higher/lower than the other.
9. **0/4~20mA Output Signal Adjustment** : Zero and Span adjustment of output signal. A power source should be connected.
10. **Measuring value** : Read the measuring value of channel 1 (PV1), channel 2 (PV2) and Math calculation of PV1, PV2 continually.
11. **Device information** : Indicate the device model, firmware version, series number and communication status.

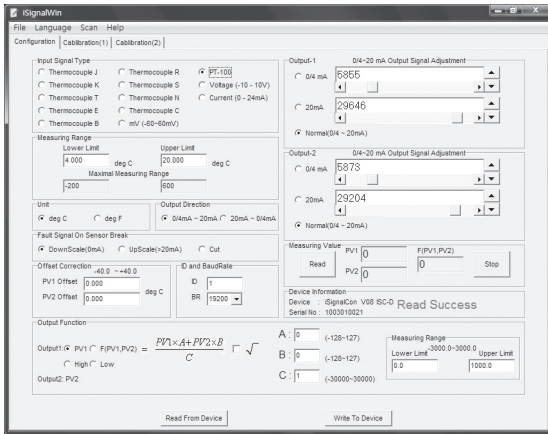

Figure 5. Configuration screen

## Accessory

URC-1020 Interface cable

