

# SD5 5 Channels Universal Monitoring Indicator

The Vertex SD5 is our new 5 channel Digital Display Indicator. It is a low cost, yet reliable, Digital Panel Indicator. You can set the scan rate between 0~10 seconds per channel or stop on one channel if required. You can also disable the channels you are not using. The SD5 comes standard with two alarms that cover all 5 inputs. RS485 comms are also available as an optional extra so that these indicators can be networked.

## 1. Front Panel and Keypad description:

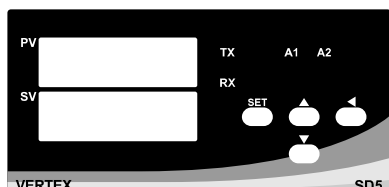

display/ indicator		indication	Description
Display	PV		1. Shows the process values PV1~PV5 2. Also displays the parameter name when selected.
Display	SV		1. Tells you which channel is being displayed in PV display above ... CH-1~CH-5 2. Also displays the parameter data/set value when selected.
Indicator	Alarm	AL1、AL2 (A1、A2) (AL、AH)	Alarm indicators. The alarm indicators will blink if you have selected the time function while timer alarm is counting time.
Indicator	TX RX	TX / RX	When the TX and RX indicators are blinking respectively it indicates that the communication function is working.

Keypad	Description
	Press once to access the next programmable parameter. Press this key for 5 seconds to reset alarm timer/ LATH RESET
	Press to increase the set value or parameter value. Press to access the last channel process value PV(scan manually)
	Press to decrease the set value or parameter value./ Press to access the next channel process value PV(scan manually)
	Shift Key
Press once together	Return to normal position
Press together for 5 seconds	Press the  keys together for 5 seconds to select programming level, then press  key to enter this level.

## 2. Initial Setup Requirements

- 2.1. Connect mains power to T23 and T24
- 2.2. Access the parameters by pressing the **SET**+**◀** keys together for 5 seconds.
- 2.3. Set the input type you will be using (it must be the same on all channels and all probes need to be the same type and use the same range.)
- 2.4. Then set the number of channels you will be using and the scan time (between 0 ~ 10 seconds) for which each input must be displayed as the scan rotates.
- 2.5. Check that the "unit" is deg C, select your decimal point preference,
- 2.6. Set the LoLt to the zero value for your measuring range. (This is not a limit as such but the low value of the measuring range and should not be set above zero)
- 2.7. Set the HiLt to the high value of your measuring range, typically 0~100 or 0~200 etc
- 2.8. The balance of these parameters are used for either alarm or RS485 comms setup and will be covered elsewhere.
- 2.9. Connect inputs to the appropriate input terminals. ie: Thermocouple on Ch1 using T10 (-ve) and T11 (+ve) or if using PT100's using T10 + T11 + T12 and so on having up to 5 inputs.
- 2.10. Now turn the power on and the unit should work as desired.
- 2.11. Note by setting the scan time to zero, you will be able to page through the different channels manually using either the up or down button.

## 3. Wiring Diagram:

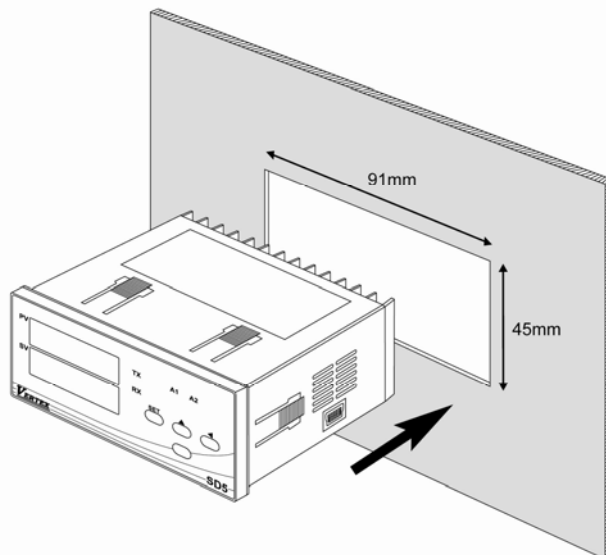
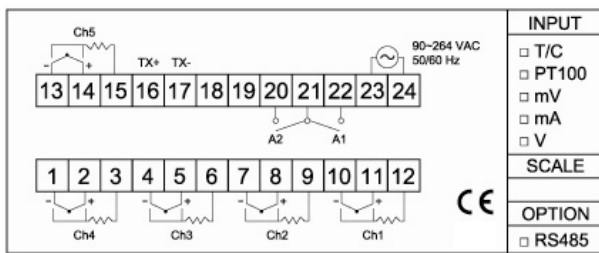

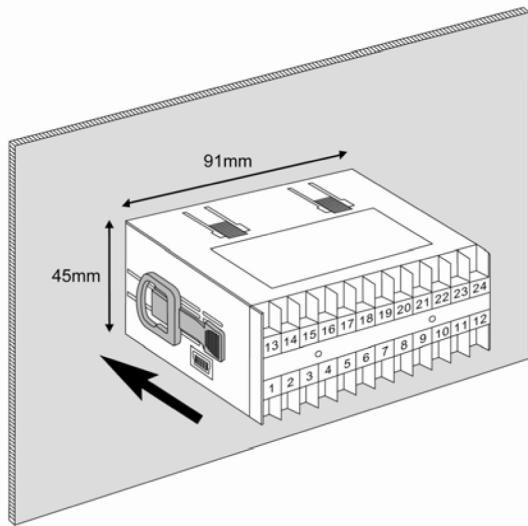

1. Before wiring, check the controller label for correct model number and options.
2. Mains power can be ac or dc between 90 and 264 volts and always goes on T23 and T24
3. Terminals T20, T21 and T22 are used for the alarms.
4. Terminals T16 and T17 are used for the RS485 comms.
5. For thermocouple input, use the appropriate compensation wire. And note the polarity of the input signal wiring
6. To avoid noise induction, keep input signal wires away from power lines.
7. Prepare the panel cutout with proper dimensions ( $92 + 0.5$  and  $45 + 0.5$  mm)

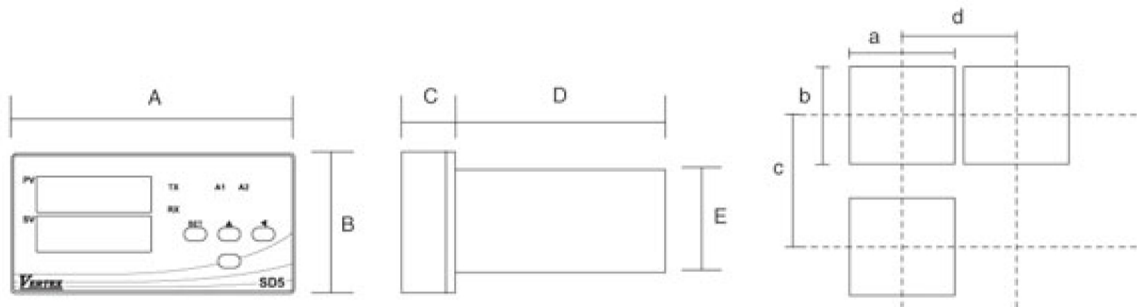

(Unit: mm)

PANEL CUTOUT :	Model	A	B	C	D	E	a	b	c	d
	SD5	96	48	9	80	45	$91^{+0.5}$	$45^{+0.5}$	48	120

#### 4. Table 1 Input type and range

TYPE	Code	RANGE( $^{\circ}C$ )		RANGE( $^{\circ}F$ )	
J	J	-50~1000	-50.0~999.9	-58~1832	-58.0~999.9
K	K	-50~1370	-50.0~999.9	-58~2498	-58.0~999.9
T	T	-270~400	-199.9~400.0	-454~752	-199.9~752.0
DPT	d-PL	-200~600	-199.9~600.0	-328~1112	-199.9~999.9
LINE	L in E	N/A			

## 5. Specifications

<b>Specifications</b>	
<b>Input</b>	Inputs are configurable between Type J, Type K and Type T RTD : DIN PT-100
<b>Ranges</b>	All 5 channels need to be the same input and range. See ranges listed below.
<b>Displays</b>	The top display shows the reading and the bottom indicates which channel it is for.
<b>Accuracy</b>	T/C $\pm$ 1°C; RTD $\pm$ 0.2°C
<b>Sampling Time</b>	0.25 second
<b>Alarm</b>	The indicator comes standard with 2 configurable alarms. These alarms work across all 5 input channels and will be activated if any one channel exceeds the set value. Rated at 10A/ 240 VAC (Resistive load)
<b>General</b>	Rated Voltage : AC 90~264VAC 50 / 60Hz
	Ambient Temperature : 0~50°C
	IP Rating: IP 65
	Ambient Humidity : 0~90 % (Non-Condensing)
	Consumption : Less than 3VA

## 6. PARAMETER LOCK

The parameter lock can be used to restrict unwanted access to the settings in your indicator

0001	Only LOCK is adjustable.
0010	Only LOCK and first level are adjustable.
0011	Second level is adjustable.
0100	All parameters are adjustable.

The "First level" starts with "A1S1" and the second level starts with "type"

## 7. Parameters Flowchart:

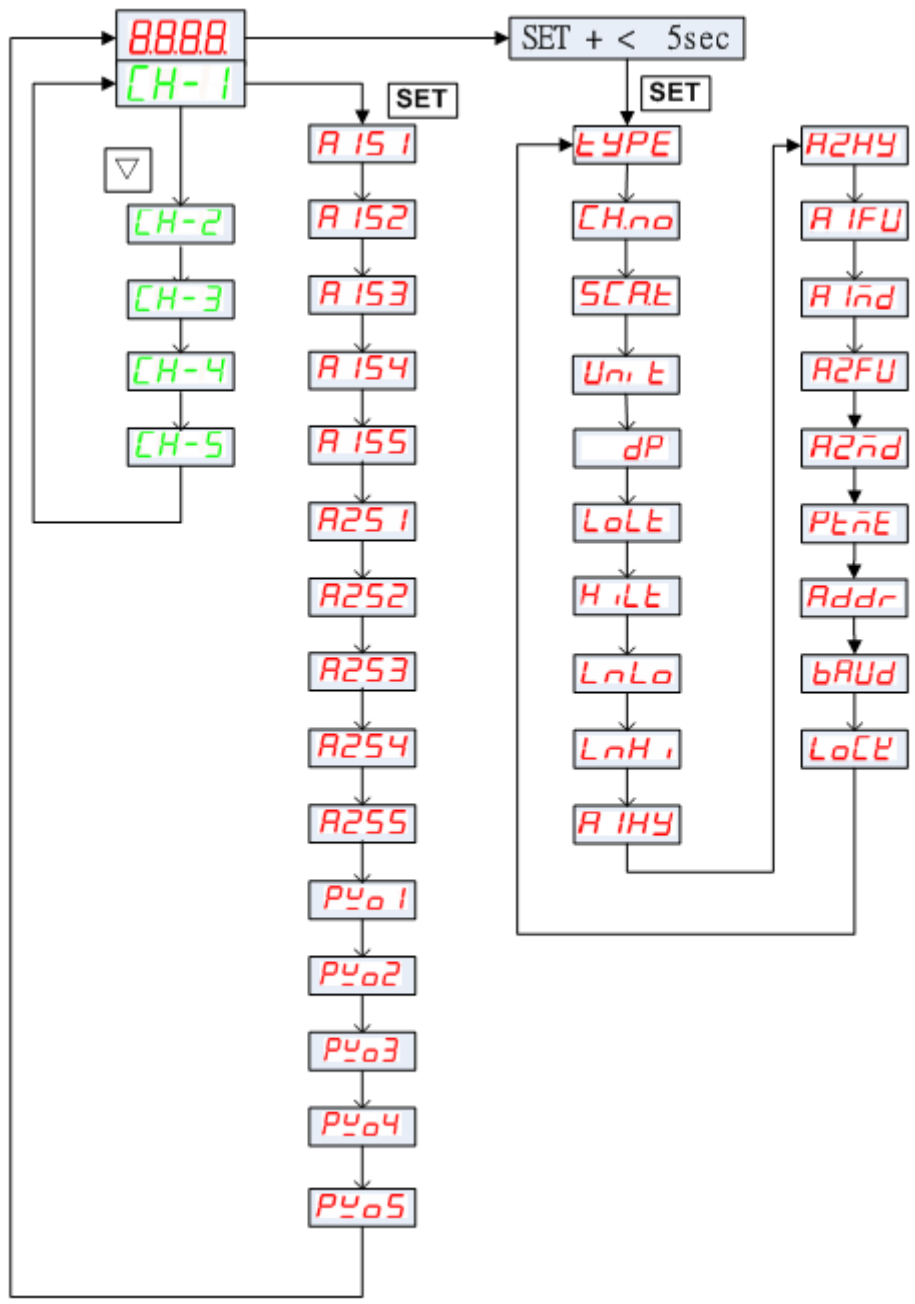

## 8. Parameter Description:

Parameter	Code	Description	Range	Default
PV	X	Process value PV1~PV5	X	X
CH-1	CH-1	Input channel 1 ; CH-1 blinking while alarm relay is on.	X	X
CH-2	CH-2	Input channel 2 ; CH-2 blinking while alarm relay is on.		
CH-3	CH-3	Input channel 3 ; CH-3 blinking while alarm relay is on.		
CH-4	CH-4	Input channel 4 ; CH-4 blinking while alarm relay is on.		
CH-5	CH-5	Input channel 5 ; CH-5 blinking while alarm relay is on.		
A1S1	A1S1	Alarm 1 set value of input channel 1	-1999—9999	500
A1S2	A1S2	Alarm 1 set value of input channel 2		
A1S3	A1S3	Alarm 1 set value of input channel 3		
A1S4	A1S4	Alarm 1 set value of input channel 4		
A1S5	A1S5	Alarm 1 set value of input channel 5		
A2S1	A2S1	Alarm 2 set value of input channel 1	-1999—9999	500
A2S2	A2S2	Alarm 2 set value of input channel 2		
A2S3	A2S3	Alarm 2 set value of input channel 3		
A2S4	A2S4	Alarm 2 set value of input channel 4		
A2S5	A2S5	Alarm 2 set value of input channel 5		
PVO1	PVO1	Process value offset of input channel 1	-1000~1000 / -100.0~100.0 / -10.00~10.00 / -1.000~1.000	0
PVO2	PVO2	Process value offset of input channel 2		
PVO3	PVO3	Process value offset of input channel 3		
PVO4	PVO4	Process value offset of input channel 4		
PVO5	PVO5	Process value offset of input channel 5		

Parameter	Code	Description	Range	Default	
tYPE	<i>tYPE</i>	Input type	Refer to Table1	<i>H</i>	
CH.no	<i>CH.no</i>	This is where you set the number of channels you are using. If 5 input channels are connected, <i>CH.no</i> is set to 5.	1~5	5	
SCA.T	<i>SCA.T</i>	Scan rate for all channels.	0~10 sec / channel Set this to 0 if you do not wish it to scan automatically.	0	
Unit	<i>Unit</i>	Measuring unit of the process value	<i>°C</i> : Degree C <i>°F</i> : Degree F	<i>°C</i>	
Dp	<i>dP</i>	Decimal point selection. (Linear input only) 0.01 and 0.001 resolution. After changing the decimal point, please reconfirm the parameter values below.	<i>0000</i>	No decimal point	<i>0000</i>
			<i>000.0</i>	0.1 resolution	
			<i>00.00</i>	0.01 resolution	
			<i>0.000</i>	0.001 resolution	
LoLt	<i>LoLt</i>	Low limit of span or range.	Refer to Table 1	0	
HiLt	<i>HiLt</i>	High limit of span or range.	Refer to Table 1	1000	
LnLo	<i>LnLo</i>	Low scale of linear input	-1999~9999(-199.9~999.9)	0	
LnHi	<i>LnHi</i>	High scale of linear input	-1999~9999(-199.9~999.9)	1000	
A1HY	<i>A1HY</i>	Hysteresis for Alarm 1. While A1FU is set to T.on or T.off, the unit will be <i>HHññ</i> 、 <i>ññSS</i> .	0~250 / 0.0~25.0 / 0.00~2.50/ 0.000~0.250 00.00~99.59	1	
A2HY	<i>A2HY</i>	Hysteresis for Alarm 2. While A2FU is set to T.on or T.off, the unit will be <i>HHññ</i> 、 <i>ññSS</i> .			
A1FU	<i>A1FU</i>	Alarm 1 function. Used alone or with alarm mode. If A1FU= <i>nonE</i> , alarm function is cancelled.	Refer to Table 2	<i>H</i>	
A1MD	<i>A1ñd</i>	Alarm 1 mode. Used with <i>A1FU</i> . If A1MD= <i>nonE</i> , alarm mode is cancelled.	Refer to Table 2	<i>nonE</i>	
A2FU	<i>A2FU</i>	Alarm 2 function. Used alone or with alarm mode. If A2FU= <i>nonE</i> , alarm function is cancelled.	Refer to Table 2	<i>Lo</i>	
A2MD	<i>A2ñd</i>	Alarm 2 mode. Used with <i>A1FU</i> . If A2MD= <i>nonE</i> , alarm mode is cancelled.	Refer to Table 2	<i>nonE</i>	
PtmE	<i>PtñE</i>	Time scale of timer alarm	<i>HHññ</i> 、 <i>ññSS</i>		
Addr	<i>Addr</i>	RS485 communication address	0~255	247	
bAUd	<i>bAUd</i>	Communication baud rate	<i>48K</i>	4800 bps	<i>192K</i>
			<i>96K</i>	9600 bps	
			<i>192K</i>	19200 bps	
			<i>384K</i>	38400 bps	
LoCK	<i>LoCK</i>	Parameter lock	Refer to 6. parameter lock		

## 9. Alarm Functions:

In the parameter settings you first encounter the *A1HY*、*A2HY* parameters.

Hysteresis setting for alarms works with *A1FU*、*A2FU* and sets a dead band below the alarm set point to avoid unnecessary tripping of the alarm.

The *A1FU*、*A2FU* settings are used to define how the alarms work. They can be used alone or in conjunction with the alarm mode parameters that dictate additional functions governing how the alarms function chosen will work. Alarm functions are as follows:

*nonE* : Alarm function is off. If the alarm function is set to *nonE*, alarm output is disabled.

*H* : Process high alarm. When  $PV \geq ALSP$ , the alarm relay is ON. When  $PV < ALSP$ , the alarm relay is OFF.

- Lo** : Process low alarm. When  $PV \leq ALSP$ , the alarm relay is ON. When  $PV > ALSP$ , the alarm relay is OFF.
- ton** : On-timer alarm. When  $PV = SP$ , the alarm relay begins to count time and the alarm relay status LED A1 blinks. When the timers counts down to zero, the alarm relay is ON and the alarm relay status LED A1 lights.
- toff** : Off-timer alarm . On powering up the controller, the alarm relay will be ON and the alarm relay status LED lights up. When the  $PV = SP$ , the alarm relay begins to count the time and the alarm relay status LED A1 blinks. When the timer counts down to zero, the alarm relay will switch OFF and the alarm relay status LED A1 will be off.

**Table 2**

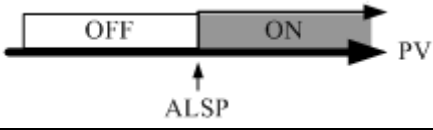
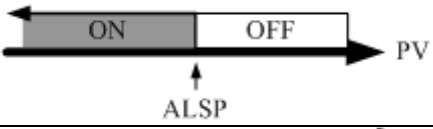
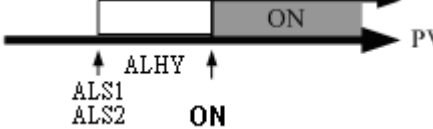
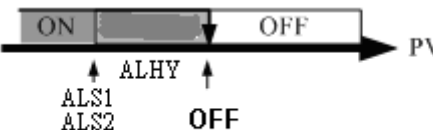
<i>A1FU A2FU</i>	Code	Alarm output operation
Alarm function off	<i>nonE</i>	
Process high alarm	<i>Hi</i>	
Process low alarm	<i>Lo</i>	
On-timer	<i>ton</i>	
Off-timer	<i>toff</i>	

### Alarm modes

The alarm mode functions *A1nd*, *A2nd* are used with the alarm functions above and work as described in the table below.

Alarm mode	Code	Description
<i>A1nd A2nd</i>	<i>nonE</i>	Disable the alarm mode
	<i>Stdy</i>	Standby mode. When selected, in any alarm function, prevents an alarm on power up. The alarm is enabled only when the process value reaches set point. Also known as “Startup inhibit” and is useful for avoiding alarm trips during startup.
	<i>LAtH</i>	Latch mode. When selected, the alarm output and indicator latch as the alarm occurs. The alarm output and indicator will not change its state even if the alarm condition has been cleared unless the power is reset (off).
	<i>StLA</i>	Both standby and Latch mode are applied.



MODBUS RTU N,8,2

Read03/Write06		
0x0000	Type	0 : J 1 : K 2 : T 3 : d-pt 4 : Line
0x0001	Unit	0 : °C 1 : °F 2 : ENG
0x0003	-----	-----
0x0004	-----	-----
0x0009	ChNo	1~5
0x000A	Scat	0~10
0x000B	Dp	Line(Type) : 0~3 etc(Type) : 0~1
0x000C	A1hy	none,Hi,Lo(A1fu) : 0~250 etc(A1fu) : 0~5999
0x000D	A2hy	none,Hi,Lo(A2fu) : 0~250 etc(A2fu) : 0~5999
0x000E	A1fu	0 : none 1 : Hi 2 : Lo 3 : ton 4 : toff
0x000F	A1md	0 : none 1 : stdy 2 : lath 3 : st.la
0x0010	A2fu	0 : none 1 : Hi 2 : Lo 3 : ton 4 : toff
0x0011	A2md	0 : none 1 : stdy 2 : lath 3 : st.la
0x0012	Ptme	0 : HH,MM 1 : MM,SS
0x0013	Lock	0~3 (Read Only)
0x0014	ID	1~255
0x0015	Baud	0 : 4.8K 1 : 9.6K 2 : 19.2K 3 : 38.4K
0x0016	A1s1	-1999~9999
0x0017	A1s2	-1999~9999
0x0018	A1s3	-1999~9999
0x0019	A1s4	-1999~9999
0x001A	A1s5	-1999~9999
0x001B	A2s1	-1999~9999
0x001C	A2s2	-1999~9999
0x001D	A2s3	-1999~9999
0x001E	A2s4	-1999~9999
0x001F	A2s5	-1999~9999
0x0020	Pvo1	Refer to Table1
0x0021	Pvo2	Refer to Table1
0x0022	Pvo3	Refer to Table1
0x0023	Pvo4	Refer to Table1
0x0024	Pvo5	Refer to Table1
Read04		
0x1000	Pv1	
0x1001	Pv2	
0x1002	Pv3	
0x1003	Pv4	
0x1004	Pv5	